

+ ( ) ..... 1  
+ ..... 1

+ ( )

x Master Device

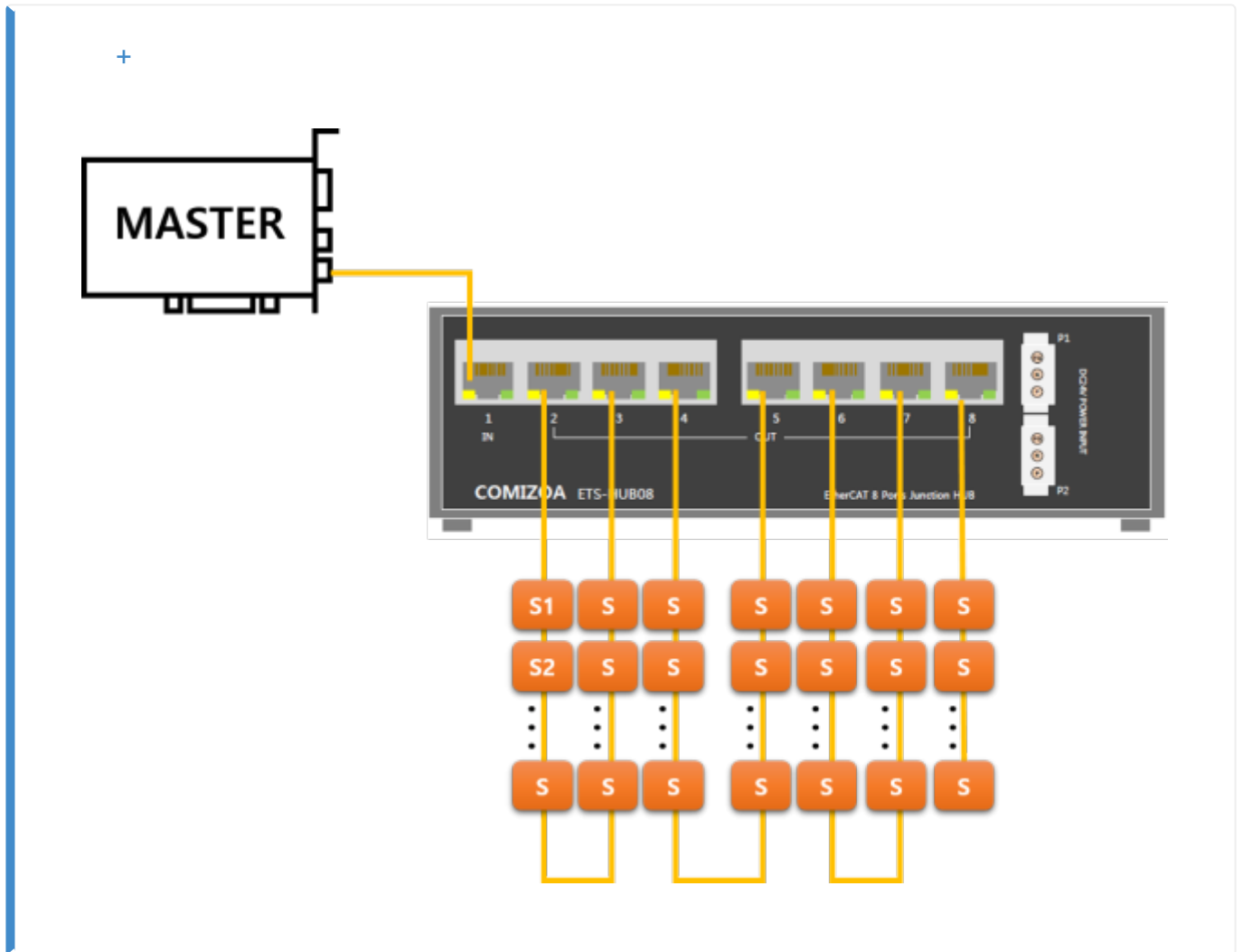

- Hub

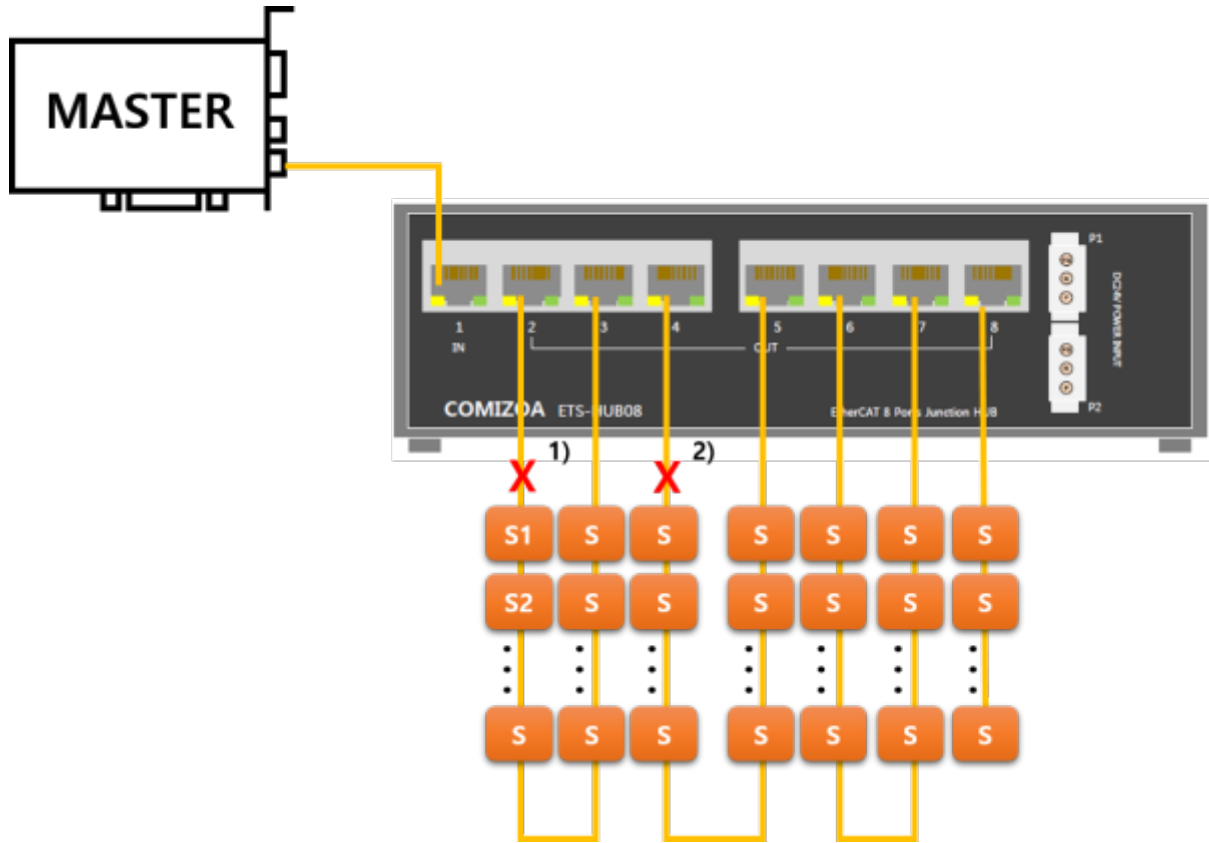

- 1), 2)

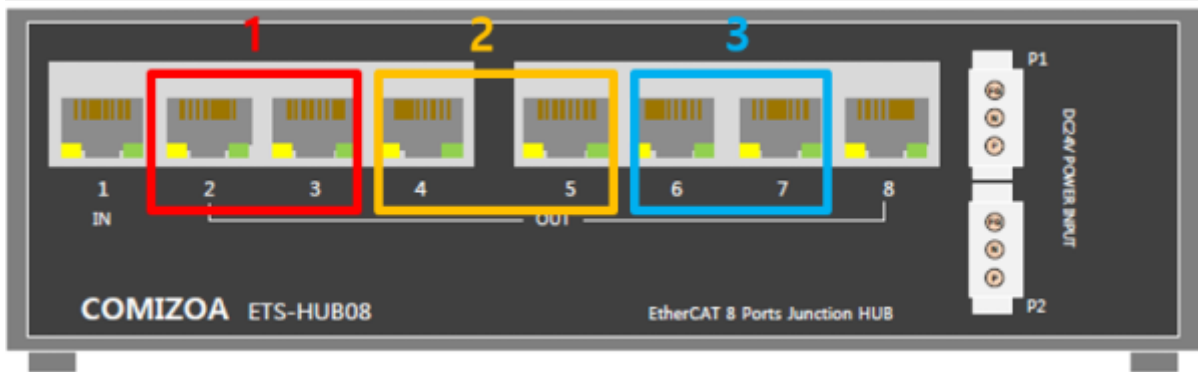

- HUB , IN / OUT
  - 2 3
  - 4 5
  - 6 7
- - 1 , 2 3 가

From:  
<http://comizoa.com/info/> - -

Permanent link:  
[http://comizoa.com/info/doku.php?id=platform:ethercat:1\\_setup:05\\_topology:50\\_treering&rev=1608096765](http://comizoa.com/info/doku.php?id=platform:ethercat:1_setup:05_topology:50_treering&rev=1608096765)

Last update: **2024/07/08 18:22**